

LM3570

Low Noise White LED Driver System

General Description

The LM3570 device provides a complete LED driver solution for wireless handsets and other portable devices using a display and keypad. With three constant current sources, up to three white LEDs can be used for display lighting with excellent current matching (0.3% typ.). The regulated 4.35V output voltage is perfect for driving auxiliary keypad LEDs in voltage mode.

The LM3570 utilizes a high efficiency 3/2 CMOS charge-pump with a pre-regulation loop that minimizes conducted noise on the input. It accepts an input voltage range from 2.7V to 5.5V and maintains a constant current determined by the current through an external R_{SET} resistor.

The device supplies up to 80mA of total load current to accommodate any combination of up to three white LEDs, and additional current from V_{OUT} . The switching frequency is set at 500kHz. (typ.) to keep the conducted noise spectrum away from sensitive frequencies within portable RF devices.

By applying a pulse width modulated (PWM) signal to the PWM pin, the user has the ability to independently control the brightness of the regulated current source outputs without shutting down the regulated output voltage.

Features

- 2.7V to 5.5V Input Voltage
- Regulated Output Voltage ($V_{OUT} = 4.35V$)
- Regulated I_{DX} with $\pm 0.3\%$ matching between constant current outputs
- High Efficiency 3/2 Boost function
- Drives one, two, or three white LEDs with no bias resistor losses
- Drives auxiliary keypad LEDs in voltage mode
- Up to 80mA total output current
- Active-High Enable
- Active-High PWM Control Pin for independent control of current sources
- Very small solution size
- 1 μA (max) shutdown current
- 500kHz switching frequency (typ.)
- Linear regulation generates predictable noise spectrum
- LLP-14 package: 4.0mm X 3.0mm X 0.8mm

Applications

- Portable devices using white or blue LEDs with display and backlight or frontlight
- 1-Cell Lilon battery-operated equipment including PDAs, hand-held PCs and cellular phones

Typical Application Circuit

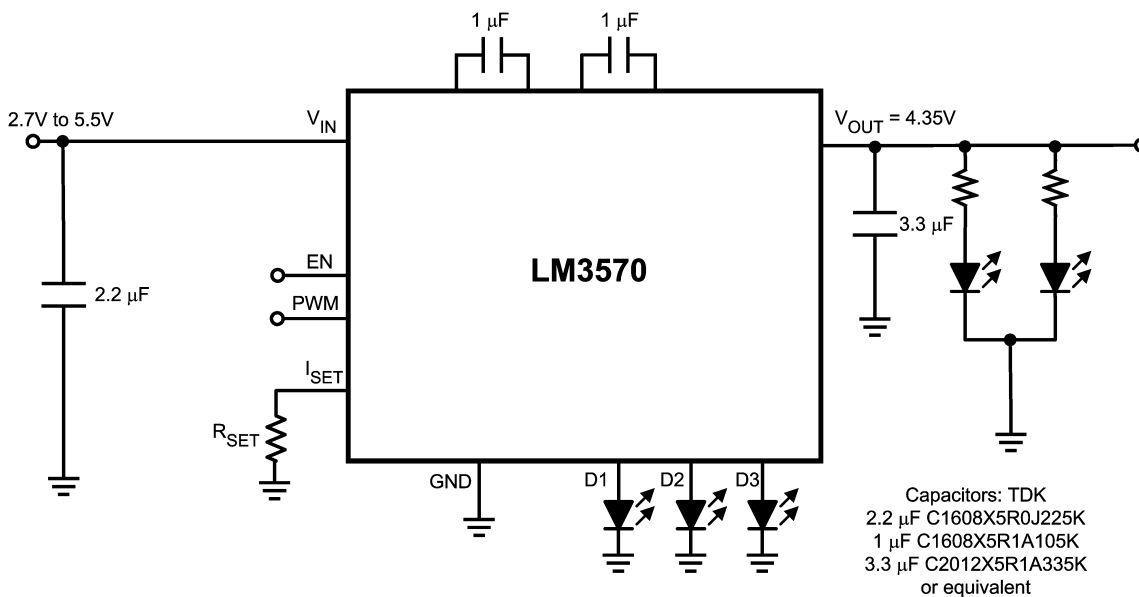

20085021

Connection Diagram

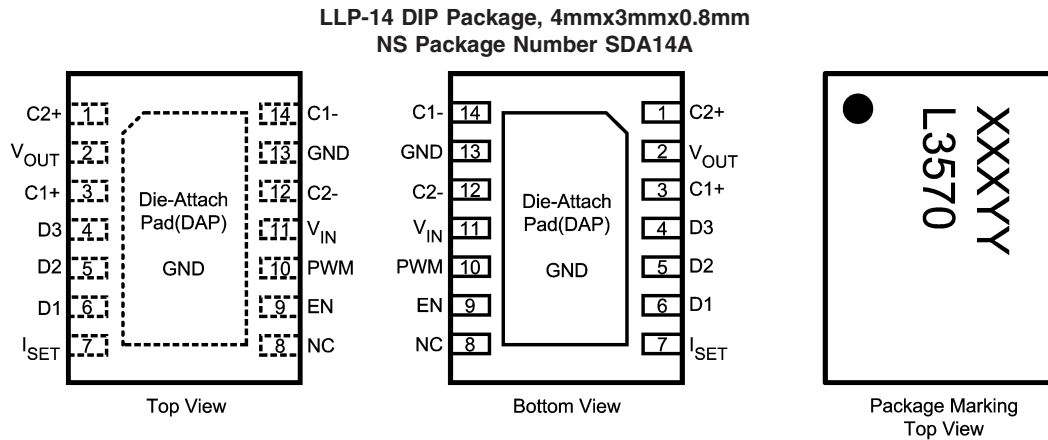

Note: The actual physical placement of the package marking will vary from part to part. The package marking "XXX" designates the date code. "YY" is a NSC internal code for die traceability. Both will vary considerably. "L3570" identifies the device (part number, option, etc.).

20085002

Pin Description

Pin#	Pin Name	Pin Description
1	C2+	Connect this pin to the positive terminal of C2.
2	V _{OUT}	Regulated Charge pump output (4.35V).
3	C1+	Connect this pin to the positive terminal of C1.
4	D3	Current source output 3. Connect directly to LED.
5	D2	Current source output 2. Connect directly to LED.
6	D1	Current source output 1. Connect directly to LED.
7	I _{SET}	Current set input. Value of resistor tied between I _{SET} and GND sets the Dx output currents.
8	NC	No Connect
9	EN	Enable Input High = On, Low = Shutdown
10	PWM	Current Source Modulation pin. High = On, Low = Off. Applying a PWM signal to this pin allows the regulated current sources to be to be modulated without shutting down the V _{OUT} pin and the remainder of the part.
11	V _{IN}	Power supply voltage input.
12	C2-	Connect this pin to the negative terminal of C2.
13	GND	Ground connection.
14	C1-	Connect this pin to the negative terminal of C1.

Ordering Information

Order Number	Package Type	Package Marking	Supplied As:
LM3570SD	SDA14A	L3570	1000 units on Tape-and-Reel
LM3570SDX	SDA14A	L3570	3500 units on Tape-and-Reel

Absolute Maximum Ratings (Notes 1, 2)

If Military/Aerospace specified devices are required, please contact the National Semiconductor Sales Office/Distributors for availability and specifications.

VIN pin: Voltage to GND	-0.3V to 6.0V
EN, PWM: Voltage to GND	-0.3V to (VIN + 0.3V) w/ 6.0V max
Continuous Power Dissipation (Note 3)	Internally Limited
Junction Temperature (T _{J-MAX})	150°C
Storage Temperature Range	-65°C to +150°C
Maximum Lead Temperature (Soldering, 10 sec.)	(Note 4)
ESD Rating (Note 5)	
Human Body Model	2.0kV
Machine Model	200V

Operating Ratings (Notes 1, 2)

Input Voltage Range	2.7V to 5.5V
Junction Temperature (T _J) Range	-40°C to +105°C
Ambient Temperature (T _A) Range (Note 6)	-40°C to +85°C

Thermal Properties

Junction-to-Ambient Thermal Resistance (θ _{JA}), LLP14 Package (Note 7)	45°C/W
---	--------

Electrical Characteristics (Notes 2, 8)

Limits in standard typeface and typical values apply for T_J = 25°C. Limits in **boldface** type apply over the operating junction temperature range. Unless otherwise noted, specifications apply to the LM3570 typical Application Circuit (pg.1) with: V_{IN} = 3.6V, V_{EN} = 3.0V, V_{PWM} = 3.0V, V_{DX} = 3.6V, R_{SET} = 6.25kΩ, C₁ = C₂ = 1.0μF, C_{IN} = 2.2μF, C_{OUT} = 3.3μF (Note 9)

Symbol	Parameter	Condition	Min	Typ	Max	Units
I _{DX}	Output Current Regulation (All Current Sources Active Total Current = 3 x I _{DX}) (Note 10)	3.0V ≤ V _{IN} ≤ 5.5V; 2.5V ≤ V _{DX} ≤ 3.6V; R _{SET} = 6.25kΩ; I _{VOUT} = 0mA	18.4	20.0	21.6	mA
		3.0V ≤ V _{IN} ≤ 5.5V; 2.5V ≤ V _{DX} ≤ 3.8V; R _{SET} = 8.35kΩ; I _{VOUT} = 0mA	13.6	15.0	16.4	
		3.0V ≤ V _{IN} ≤ 5.5V; 2.5V ≤ V _{DX} ≤ 3.9V; R _{SET} = 12.5kΩ; I _{VOUT} = 0mA		10.0		
V _{OUT}	Regulated Output Voltage	3.3V ≤ V _{IN} ≤ 5.5V; 0mA ≤ I _{Total} ≤ 80mA (Note 11)	4.1	4.3	4.6	V
I _{DX-MATCH}	Current Matching Between Any Two Outputs (Note 12)			0.3		%
V _{HR}	Current Source Headroom Voltage (Note 13)	I _{DX} = 95% x I _{DX} (nom.); R _{SET} = 6.25kΩ; (I _{DX} (nom.) ≈ 20mA)		500		mV
		I _{DX} = 95% x I _{DX} (nom.); R _{SET} = 8.35kΩ; (I _{DX} (nom.) ≈ 15mA)		375		
I _Q	Quiescent Supply Current	3.0V ≤ V _{IN} ≤ 5.5V; R _{SET} = open; No Load Current		1.5	2.0	mA
		3.0V ≤ V _{IN} ≤ 5.5V; R _{SET} = 6.25kΩ; No Load Current		1.8		
I _{SD}	Shutdown Supply Current	3.0V ≤ V _{IN} ≤ 5.5V; V(EN) = 0V, V(PWM) = 0V (Note 14)		0.1	1.0	μA
R _{OUT}	Charge Pump Output Resistance	3.0V ≤ V _{IN} ≤ 5.5V		4		Ω

Electrical Characteristics (Notes 2, 8) (Continued)

Limits in standard typeface and typical values apply for $T_J = 25^\circ\text{C}$. Limits in **boldface** type apply over the operating junction temperature range. Unless otherwise noted, specifications apply to the LM3570 typical Application Circuit (pg.1) with: $V_{IN} = 3.6\text{V}$, $V_{EN} = 3.0\text{V}$, $V_{PWM} = 3.0\text{V}$, $V_{DX} = 3.6\text{V}$, $R_{SET} = 6.25\text{k}\Omega$, $C_1 = C_2 = 1.0\mu\text{F}$, $C_{IN} = 2.2\mu\text{F}$, $C_{OUT} = 3.3\mu\text{F}$ (Note 9)

Symbol	Parameter	Condition	Min	Typ	Max	Units
V_{SET}	I_{SET} Pin Voltage			1.25		V
I_{DX} / I_{SET}	Output Current to Current Set Ratio			100		
f_{SW}	Switching Frequency (Note 15)	$3.0\text{V} \leq V_{IN} \leq 5.5\text{V}$	300	500	665	kHz
t_{START}	Start-up Time	$I_{DX} = 90\%$ steady state		250		μs

EN and PWM Pin Characteristics

V_{EN-IL}	Enable Pin Logic Low	$3.0\text{V} \leq V_{IN} \leq 5.5\text{V}$	0		0.5	V
V_{EN-IH}	Enable Pin Logic High	$3.0\text{V} \leq V_{IN} \leq 5.5\text{V}$	1.0		V_{IN}	V
V_{PWM-IL}	PWM Pin Logic Low	$3.0\text{V} \leq V_{IN} \leq 5.5\text{V}$	0		0.5	V
V_{PWM-IH}	PWM Pin Logic High	$3.0\text{V} \leq V_{IN} \leq 5.5\text{V}$	1.0		V_{IN}	V
$I_{LEAK-EN}$	Enable Pin Leakage Current (Note 14)			10		μA
$I_{LEAK-PWM}$	PWM Pin Leakage Current (Note 14)			10		μA

Note 1: Absolute Maximum Ratings indicate limits beyond which damage to the component may occur. Operating Ratings are conditions under which operation of the device is guaranteed. Operating Ratings do not imply guaranteed performance limits. For guaranteed performance limits and associated test conditions, see the Electrical Characteristics tables.

Note 2: All voltages are with respect to the potential at the GND pin.

Note 3: Internal thermal shutdown circuitry protects the device from permanent damage. Thermal shutdown engages at $T_J = 150^\circ\text{C}$ (typ.) and disengages at $T_J = 140^\circ\text{C}$ (typ.).

Note 4: For detailed soldering specifications and information, please refer to National Semiconductor **Application Note 1187: Leadless Leadframe Package (LLP)**.

Note 5: The Human body model is a 100pF capacitor discharged through a 1.5k Ω resistor into each pin. (MIL-STD-883 3015.7) The machine model is a 200pF capacitor discharged directly into each pin. (EAIJ)

Note 6: In applications where high power dissipation and/or poor package thermal resistance is present, the maximum ambient temperature may have to be derated. Maximum ambient temperature (T_{A-MAX}) is dependent on the maximum operating junction temperature ($T_{J-MAX-OP} = 125^\circ\text{C}$), the maximum power dissipation of the device in the application (P_{D-MAX}), and the junction-to ambient thermal resistance of the part/package in the application (θ_{JA}), as given by the following equation: $T_{A-MAX} = T_{J-MAX-OP} - (\theta_{JA} \times P_{D-MAX})$.

Note 7: Junction-to-ambient thermal resistance is highly application and board-layout dependent. In applications where high maximum power dissipation exists, special care must be paid to thermal dissipation issues in board design. For more information on these topics, please refer to **Application Note 1187: Leadless Leadframe Package (LLP)** and the PCB Layout Considerations and Power Dissipation section of this datasheet.

Note 8: Min and Max limits are guaranteed by design, test, or statistical analysis. Typical (Typ) numbers are not guaranteed, but do represent the most likely norm. Unless otherwise specified, conditions for Typ specifications are: $V_{IN} = 3.6\text{V}$ and $T_A = 25^\circ\text{C}$.

Note 9: C_{IN} , C_{OUT} , C_1 , and C_2 : Low-ESR Surface-Mount Ceramic Capacitors (MLCCs) used in setting electrical characteristics

Note 10: Maximum $I_{DX} = 20\text{mA}$

Note 11: I_{TOT} is equal to the sum of all I_{DX} currents and the current drawn from V_{OUT} . Current can be drawn from any combination of V_{OUT} and I_{D1} , I_{D2} , and I_{D3} as long as the maximum current does not exceed 80mA.

Note 12: For the group of the three outputs on a part the following are determined: the maximum output current in the group (MAX), the minimum output current in the group (MIN), and the average output current of the group (AVG). Two matching numbers are calculated: $(MAX-AVG)/AVG$ and $(AVG-MIN)/AVG$. The largest number of the two (worst case) is considered the matching figure for the group. The matching figure for a given part is considered to be the highest matching figure. The typical specification provided is the most likely norm of the matching figure for all parts.

Note 13: Headroom Voltage is defined as the amount of voltage required across the regulated current sources in order to guarantee the full amount of output current is realized. $V_{OUT} - V_{DX} = V_{HR}$. The minimum headroom required is defined as follows: $V_{HR}(\text{min}) \geq k_{HR} \times I_{DX}$ where k_{HR} is the headroom proportionality constant and I_{DX} is the desired controlled diode current. The LM3570 has a $k_{HR} = 25\text{mV/mA}$. For more information, please refer to the output current section of this datasheet.

Note 14: The EN and PWM pins have 300k Ω internal pull-down resistors. When the part is in shutdown, the PWM pin must be tied low to ensure lowest possible shutdown current.

Note 15: The output switches operate at one eighth of the oscillator frequency, $f_{OSC} = 8f_{SW}$

Block Diagram

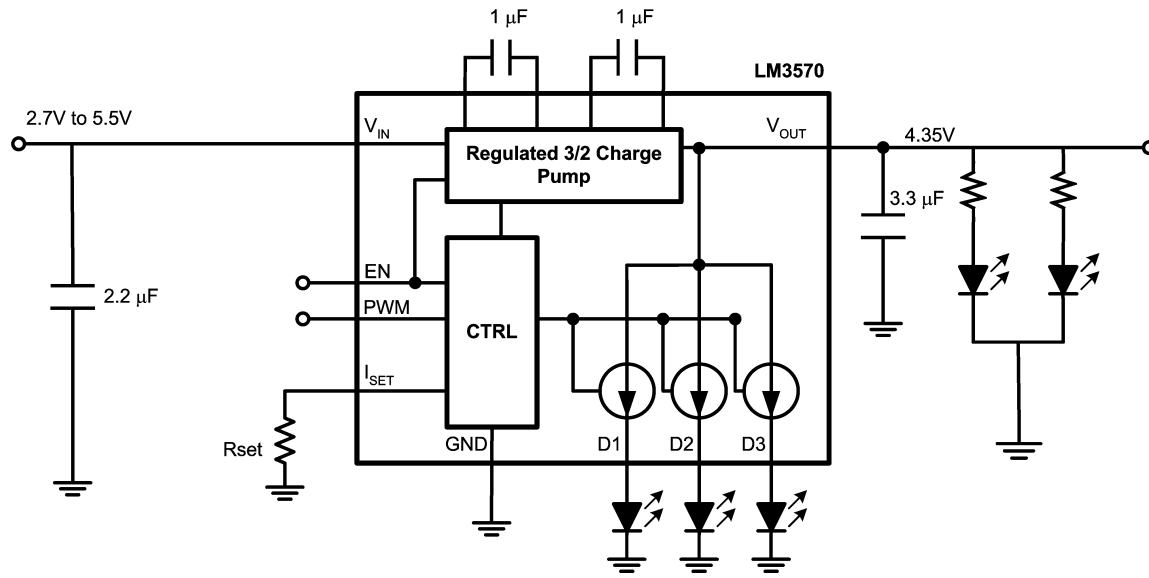

20085001

Typical Performance Characteristics

Unless otherwise specified: $V_{IN} = 3.6V$, $V_{PWM} = 3.0V$, $V_{EN} = 3.0V$, $V_{DX} = 3.6V$, $R_{SET} = 8.35k\Omega$, $T_A = 25^\circ C$

Unless otherwise specified: $V_{IN} = 3.6V$, $V_{PWM} = 3.0V$, $V_{EN} = 3.0V$, $V_{DX} = 3.6V$, $R_{SET} = 8.35k\Omega$, $T_A = 25^\circ C$

Output Voltage vs. Input Voltage

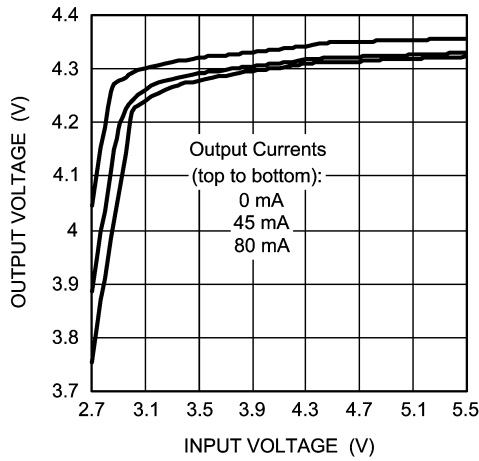

20085009

Output Voltage vs. Input Voltage

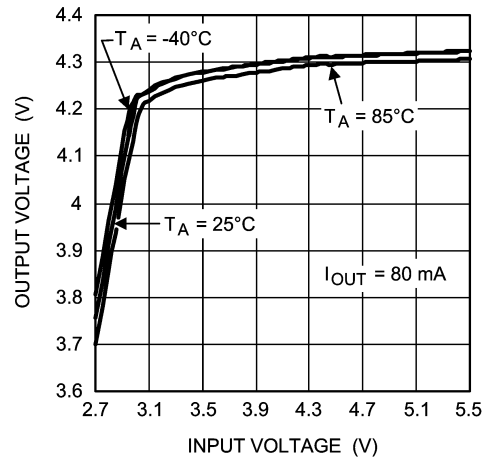

20085013

Output Voltage vs. Output Current

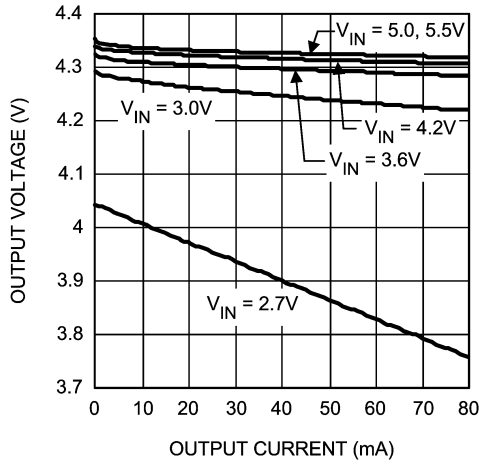

20085010

Output Voltage vs. Output Current

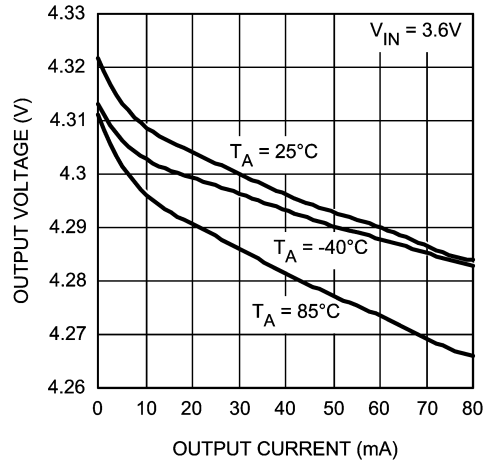

20085014

Diode Output Current vs. Input Voltage

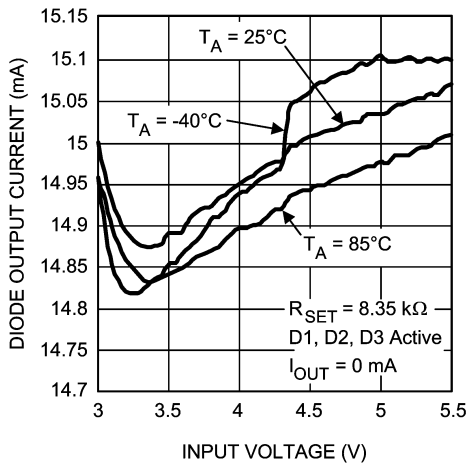

20085020

Quiescent Current vs. Input Voltage

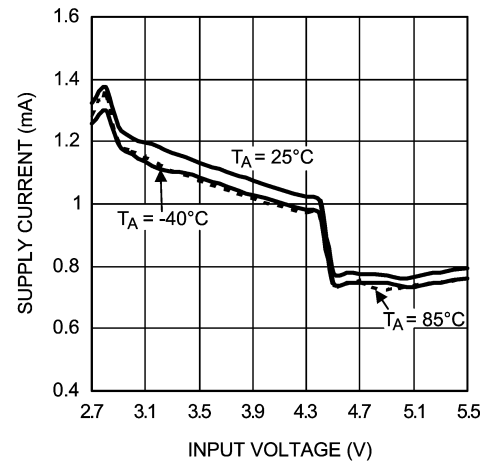

20085026

Typical Performance Characteristics Unless otherwise specified: $V_{IN} = 3.6V$, $V_{PWM} = 3.0V$, $V_{EN} = 3.0V$, $V_{DX} = 3.6V$, $R_{SET} = 8.35k\Omega$, $T_A = 25^\circ C$ (Continued)

Diode Output Current vs. LED Forward Voltage

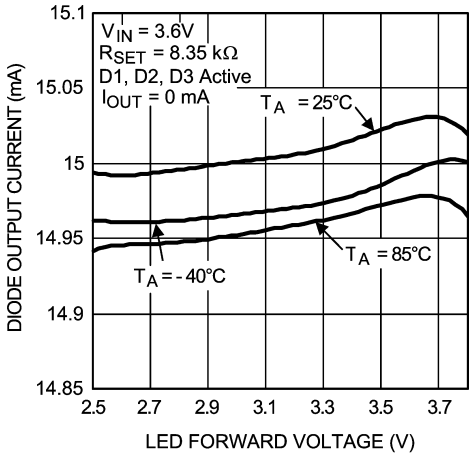

20085019

Charge Pump Efficiency vs Input Voltage

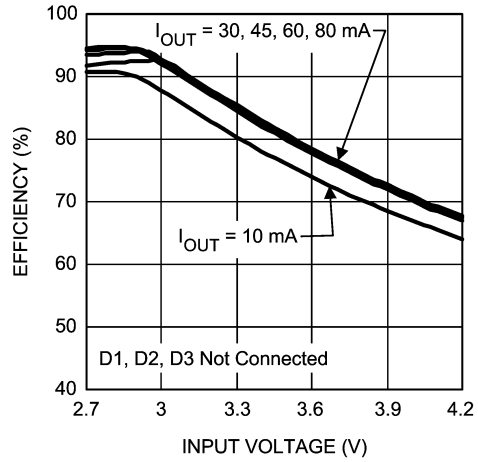

20085011

Total Efficiency vs Input Voltage

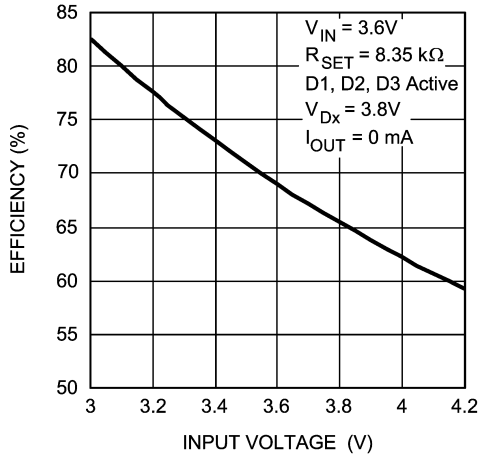

20085015

Total Efficiency vs Diode Forward Voltage

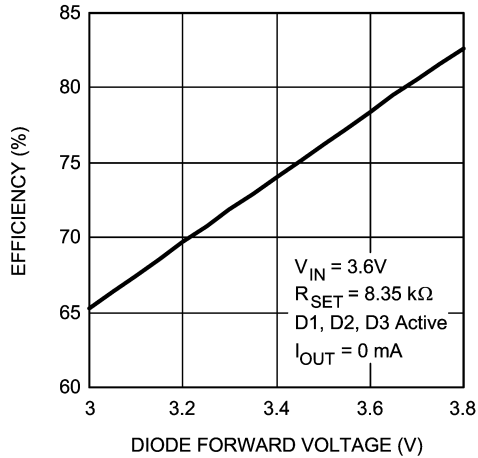

20085016

Output Current vs RSET

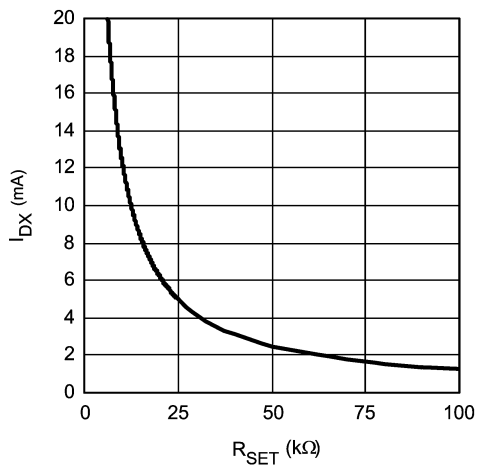

20085018

Output Current vs Headroom Voltage

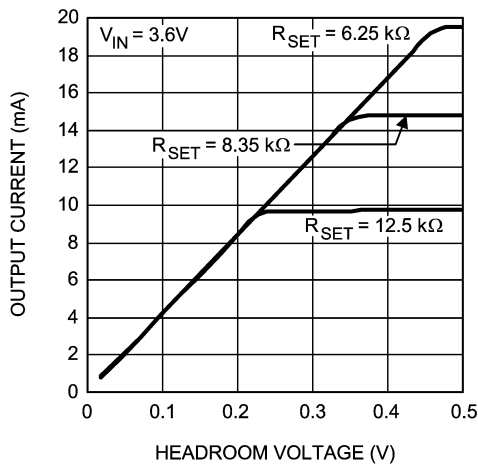

20085008

Typical Performance Characteristics Unless otherwise specified: $V_{IN} = 3.6V$, $V_{PWM} = 3.0V$, $V_{EN} = 3.0V$, $V_{DX} = 3.6V$, $R_{SET} = 8.35k\Omega$, $T_A = 25^\circ C$ (Continued)

Output Current vs Headroom Voltage

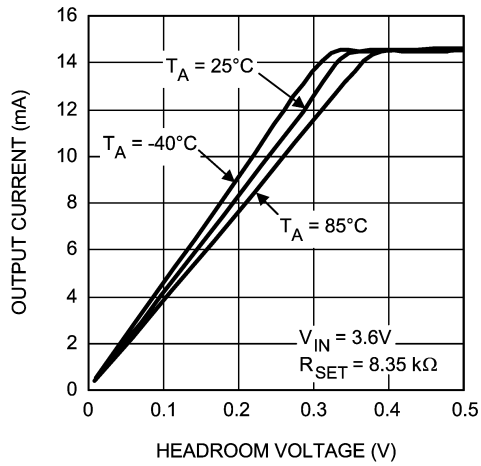

20085012

Output Current vs PWM Duty Cycle (1kHz)

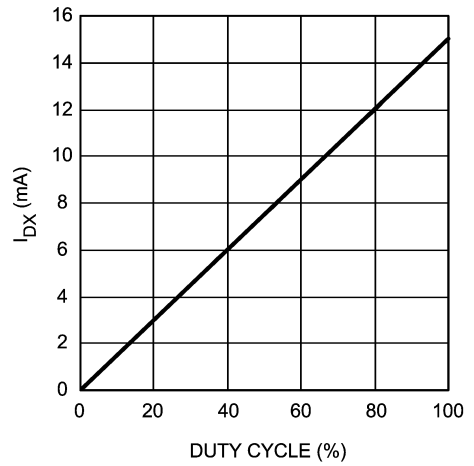

20085017

Startup Response

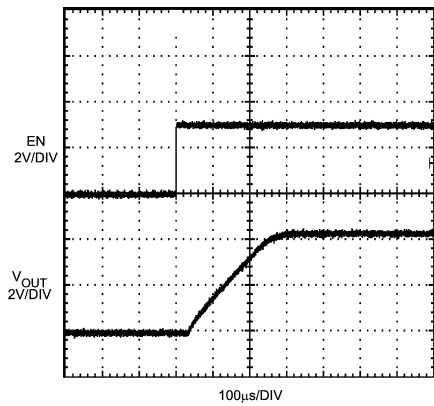

20085022

Line Step- Output Response

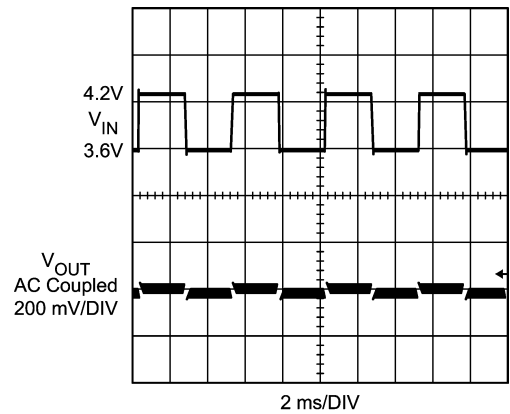

20085023

Load Step- Input and Output Response

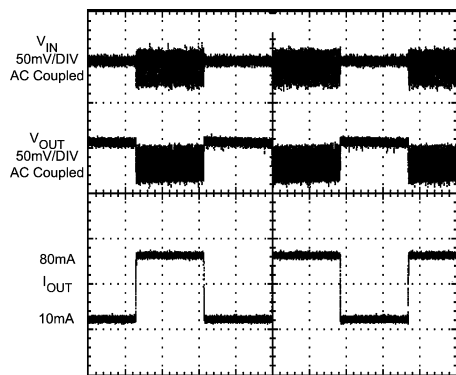

20085024

Detailed Block Diagram

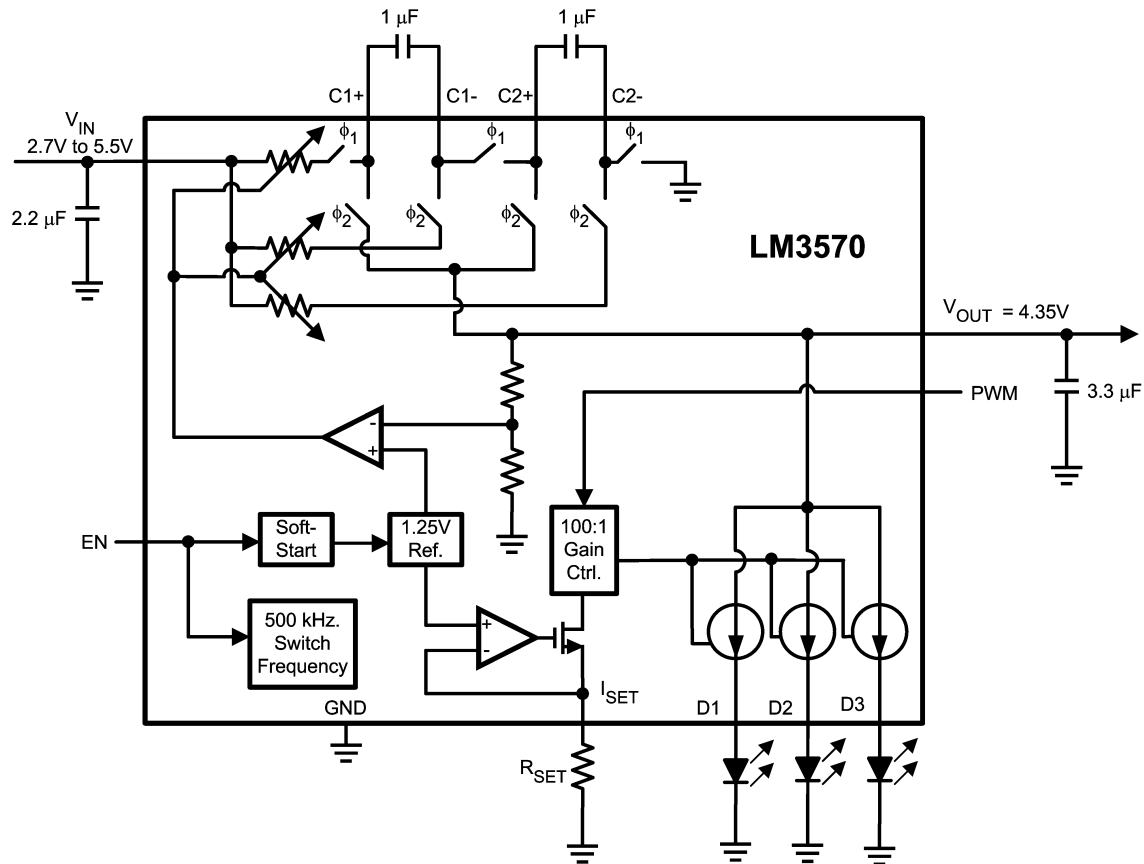

20085003

Circuit Description

The LM3570 is a low noise white LED driver system. The LM3570 system revolves around a highly efficient regulated three halves CMOS charge pump producing a output voltage (V_{OUT}) of 4.35V. For input voltages between 3.0V to 5.5V, regulation of the output voltage is achieved through the use of a pre-regulation loop that produces a stable output voltage while also minimizing conducted noise on the input rail. For voltages between 2.7V and 3.0V, the LM3570 behaves like an open loop 3/2 charge pump where the output will be 1.5X the input voltage minus the losses associated with the output resistance ($R_{OUT} \approx 4\Omega$).

Connected to the regulated output are three internal tightly matched current sources ideal for driving white LEDs. The amount of current driven through the LEDs is user selectable through the use of one external R_{SET} resistor. Current matching between adjacent outputs on the LM3570 is $\pm 0.3\%$ (typ.) allowing for uniform brightness across the LEDs. The LM3570 is capable of delivering up to 80mA of total output current. Current may be pulled out of the dedicated current outputs (I_{Dx}) or from V_{OUT} . The fixed output voltage rail is ideal for driving keypad LEDs in voltage mode through the use of external current limit resistors.

Application Information

PRE-REGULATION

The very low input current ripple of the LM3570, resulting from internal pre-regulation, adds very little noise to the input line. The core of the LM3570 is very similar to that of a basic 3/2 switched capacitor regulator: it is composed of seven switches and two flying capacitors (external). Regulation is achieved by modulating the on-resistance of the three switches connected to the input pin (one switch in phase one and two in phase two). The regulation is done before the voltage “gain stage”, giving rise to the term “pre-regulation”. Pre-regulation eliminates most of the input current ripple that is a typical and undesirable characteristic of many switched capacitor converters.

TOTAL OUTPUT CURRENT CAPABILITY

The LM3570 is capable of providing a total output current of 80mA. The 80mA can be divided through any combination of the three dedicated current outputs and/or current drawn from the V_{OUT} output. When pulling current from the V_{OUT} pin, the LM3570 will hold the output voltage at the regulated 4.35V. This pre-regulation occurs when the input voltage is within the 3.0V to 5.5V operating range. If the input voltage is between the 2.7V to 3.0V range, the V_{OUT} voltage will behave in the same manner as the output of an unregulated charge pump. During operation in this input voltage range, the output voltage becomes directly related to the total output current drawn from the part and the output resistance (R_{OUT}) of the charge pump. Figure 1 displays how the LM3570's R_{OUT} is modeled to solve for the V_{OUT} voltage

$$V_{OUT} = (V_{IN} \times 1.5) - ((I_{Dx-Total} + I_{OUT}) \times R_{OUT})$$

where $2.7V \leq V_{IN} < 3.0V$ and $R_{OUT} = 4\Omega$

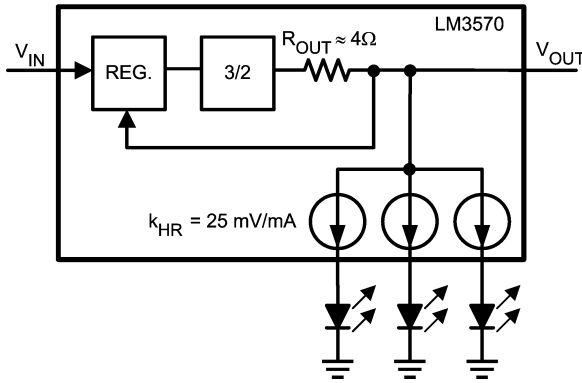

FIGURE 1. LM3570 Charge Pump Model

Dx OUTPUT CURRENT CAPABILITY

An external resistor, R_{SET}, is connected to the I_{SET} pin to set the current to be mirrored in each of the three LED outputs. The internal current mirror sets each LED output current with a 100:1 ratio to the current through R_{SET}. The current mirror circuitry matches the current through each LED to within 0.5%. An equation for approximating the LED current is:

$$R_{SET} = 100 \times (1.25V / I_{Dx})$$

PARALLEL Dx OUTPUTS FOR INCREASED CURRENT CAPABILITY

Outputs D₁ through D₃ may be connected together in any combination to drive higher currents through fewer LEDs. For example in Figure 2, outputs D₂ and D₃ are connected together to drive one LED while D₁ is connected to a separate LED.

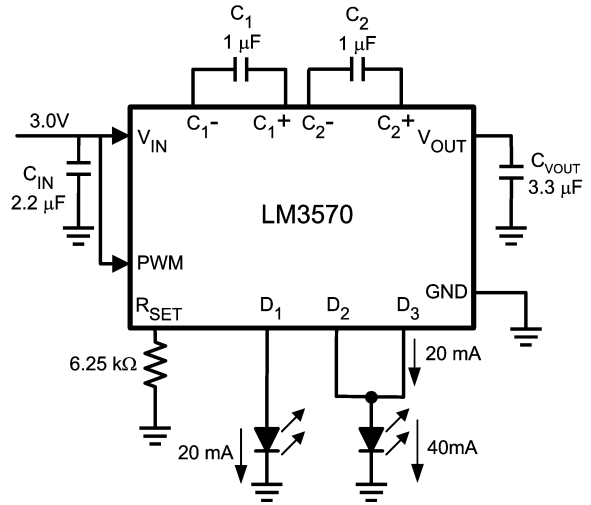

FIGURE 2. One Parallel Connected and One Singular Connected LED

With this configuration, two parallel current sources of equal value provide current to one of the LEDs. R_{SET} should therefore be chosen so that the current through each output is programmed to 50% of the desired current through the parallel connected LED. For example, if 40mA is the desired drive current for the parallel connected LED, R_{SET} should be selected so that the current through each of the outputs is 20mA. Other combinations of parallel outputs may be implemented in similar fashions, such as in Figure 3.

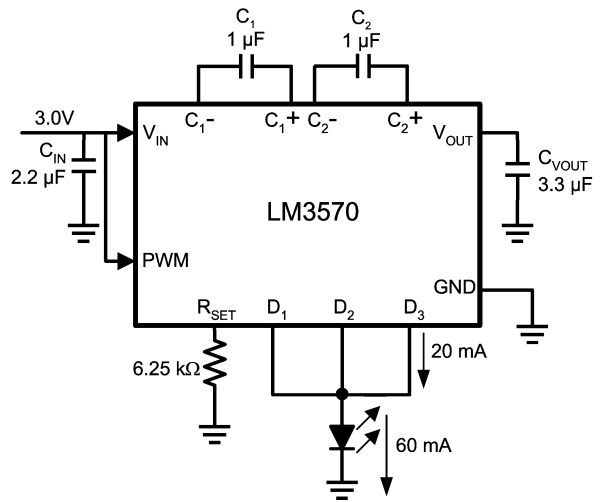

FIGURE 3. One Parallel Connected LED

Connecting outputs in parallel does not affect internal operation of the LM3570 and has no impact on the Electrical

Application Information (Continued)

Characteristics and limits previously presented. The available diode output current, maximum diode voltage, and all other specifications provided in the Electrical Characteristics table apply to parallel output configurations, just as they do to the standard 3-LED application circuit.

LED HEADROOM VOLTAGE (V_{HR})

Three current sources are connected internally between V_{OUT} and D_1 - D_3 . The voltage across each current source, ($V_{OUT} - V_{DX}$), is referred to as headroom voltage (V_{HR}). The current sources require a sufficient amount of headroom voltage to be present across them in order to regulate properly. Minimum required headroom voltage is proportional to the current flowing through the current source, as dictated by the equation:

$$V_{HR-MIN} = k_{HR} \times I_{DX}$$

The parameter k_{HR} , typically 25mV/mA in the LM3570, is a proportionality constant that represents the ON-resistance of the internal current mirror transistors. For worst-case design calculations, using a k_{HR} of 30mV/mA is recommended. (Worst-case recommendation accounts for parameter shifts from part-to-part variation and applies over the full operating temperature range). Figure 4 shows how output current of the LM3570 varies with respect to headroom voltage.

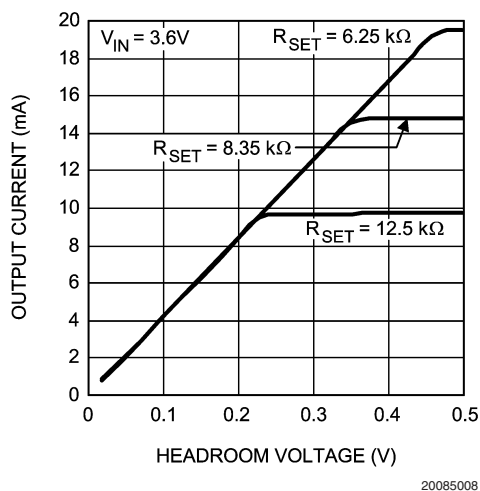

**FIGURE 4. I_{LED} vs V_{HR}
3 LEDs, $V_{IN} = 3.6V$**

On the flat part of the graph, the currents regulate properly as there is sufficient headroom voltage for regulation. On the sloping part of the graph the headroom voltage is too small, the current sources are squeezed, and their current drive capability is limited. Changes in headroom voltage from one output to the next, possible with LED forward voltage mismatch, will result in different output currents and LED brightness mismatch. Thus, operating the LM3570 with insufficient headroom voltage across the current sources should be avoided.

**TABLE 1. I_{DX} , R_{SET} and V_{HR-MIN}
 $k_{HR} = 30$ mV/mA (worst-case), $V_{OUT} = 4.3V$**

I_{OUT}	R_{SET}	$V_{HEADROOM}$
10mA	12.4kΩ	300mV

I_{OUT}	R_{SET}	$V_{HEADROOM}$
15mA	8.35kΩ	450mV
25mA	6.25kΩ	750mV

SOFT START

Soft start is implemented internally by ramping the reference voltage more slowly than the applied voltage. During soft start, the current through the LED outputs and the V_{OUT} voltage will ramp up in proportion to the rate that the reference voltage is being ramped up.

ENABLE / SHUTDOWN

When the voltage on the active-high-logic enable pin (EN) is low, the LM3570 will be in shutdown. While disabled, the LM3570 typically draws 0.1μA. When the EN pin is unconnected, the part automatically goes into shutdown due to an internal 300kΩ pull-down resistor that is tied between EN and GND. When the part is in shutdown, it is important to have the PWM pin also set to ground to avoid a leakage current resulting from an internal 300kΩ pull-down resistor tied between the PWM pin and ground.

PWM Pin

The PWM pin on the LM3570 is responsible for turning the three constant current sources (D_1 - D_3) on or off without disabling the charge pump. This pin allows for PWM brightness control on the diode outputs without affecting whatever load is tied to the V_{OUT} pin. The PWM pin has an internal 300kΩ pull-down resistor that by default turns off the diode outputs when no control signal is active.

I_{DX} CURRENT SELECTION PROCEDURES USING THE PWM PIN

The following procedures illustrate how to set and adjust output current levels using the PWM pin.

Brightness Control Using PWM

- Determine the maximum desired I_{LED} current. Use the I_{DX} equation to calculate R_{SET} .
- Brightness control can be implemented by pulsing a signal at the PWM pin. LED brightness is proportional to the duty cycle (D) of the PWM signal. For linear brightness control over the full duty cycle adjustment range, the PWM frequency (f) should be limited to accommodate the turn-on time ($T_{ON} = 100\mu s$) of the current sources.

$$D \times (1/f) > T_{ON}$$

$$f_{MAX} = D_{MIN} \div T_{ON}$$

If the PWM frequency is much less than 100Hz, flicker may be seen in the LEDs. For the LM3570, zero duty cycle will turn off the LEDs and a 50% duty cycle will result in an average I_{LED} being half of the programmed LED current. For example, if R_{SET} is set to program 15mA, a 50% duty cycle will result in an average I_{LED} of 7.5mA.

CAPACITOR SELECTION

The LM3570 requires 4 external capacitors for proper operation ($C_1=C_2=1\mu F$, $C_{IN} = 2.2\mu F$, $C_{OUT}=3.3\mu F$). Surface-mount multi-layer ceramic capacitors are recommended. These capacitors are small, inexpensive and have very low equivalent series resistance ($\leq 10m\Omega$ typ.). Tantalum capacitors, OS-CON capacitors, and aluminum electrolytic capacitors generally are not recommended for use with the LM3570 due to

Application Information (Continued)

their high ESR, as compared to ceramic capacitors. For most applications, ceramic capacitors with X7R or X5R temperature characteristic are preferred for use with the LM3570. These capacitors have tight capacitance tolerance (as good as $\pm 10\%$), and hold their value over temperature (X7R: $\pm 15\%$ over -55°C to 125°C ; X5R: $\pm 15\%$ over -55°C to 85°C). Capacitors with Y5V and/or Z5U temperature characteristic are generally not recommended. These types of capacitors typically have wide capacitance tolerance ($+80\%$, -20%), vary significantly over temperature (Y5V: $+22\%$, -82% over -30°C to $+85^{\circ}\text{C}$ range; Z5U: $+22\%$, -56% over $+10^{\circ}\text{C}$ to $+85^{\circ}\text{C}$ range), and have poor voltage coefficients. Under some conditions, a nominal $1\mu\text{F}$ Y5V or Z5U capacitor could have a capacitance of only $0.1\mu\text{F}$. Such detrimental deviation is likely to cause these Y5V and Z5U of capacitors to fail to meet the minimum capacitance requirements of the LM3570.

POWER DISSIPATION

The maximum allowable power dissipation that this package is capable of handling can be determined as follows:

$$P_{\text{DMax}} = (T_{\text{JMax}} - T_{\text{A}}) / \theta_{\text{JA}}$$

Where T_{JMAX} is the maximum junction temperature, T_{A} is the ambient temperature, and θ_{JA} is the junction-to-ambient thermal resistance of the specified package. The LM3570 comes in the LLP-14 package that has a junction-to-ambient thermal resistance (θ_{JA}) equal to $45^{\circ}\text{C}/\text{W}$. This value of θ_{JA} is highly dependant upon the layout of the PC board (See the PCB Layout Considerations section of this datasheet for more information). The actual power dissipated by the LM3570 follows the equation:

$$P_{\text{DISS}} = (V_{\text{IN}} \times I_{\text{IN}}) - (N(V_{\text{DX}} \times I_{\text{DX}}) - (V_{\text{OUT}} \times I_{\text{OUT}}))$$

Where N equals the number of active outputs, V_{DX} is the LED forward voltage, I_{DX} is the current supplied to the diode by the Dx outputs, V_{OUT} is the LM3570 output voltage (typ. = 4.35V), and I_{OUT} is the current draw directly from the LM370 charge pump. Power dissipation must be less than that allowed by the package. Please refer to the Absolute Maximum Rating of the LM3570.

THERMAL PROTECTION

The LM3570 has internal thermal protection circuitry to disable the part if the junction temperature exceeds 150°C . This feature will protect the device from damage due to excessive power dissipation. The device will recover and operate normally when the junction temperature falls below 140°C . It is important to have good thermal conduction with a proper layout to reduce thermal resistance.

PCB LAYOUT CONSIDERATIONS

The LLP is a leadframe based Chip Scale Package (CSP) with very good thermal properties. This package has an exposed DAP (die attach pad) at the center of the package measuring $3.0\text{mm} \times 1.6\text{mm}$. The main advantage of this exposed DAP is to offer lower thermal resistance when it is soldered to the thermal land on the PCB. For PCB layout, National highly recommends a 1:1 ratio between the package and the PCB thermal land. To further enhance thermal conductivity, the PCB thermal land may include vias to a ground plane. For more detailed instructions on mounting LLP packages, please refer to National Semiconductor Application Note AN-1187.

Physical Dimensions inches (millimeters) unless otherwise noted

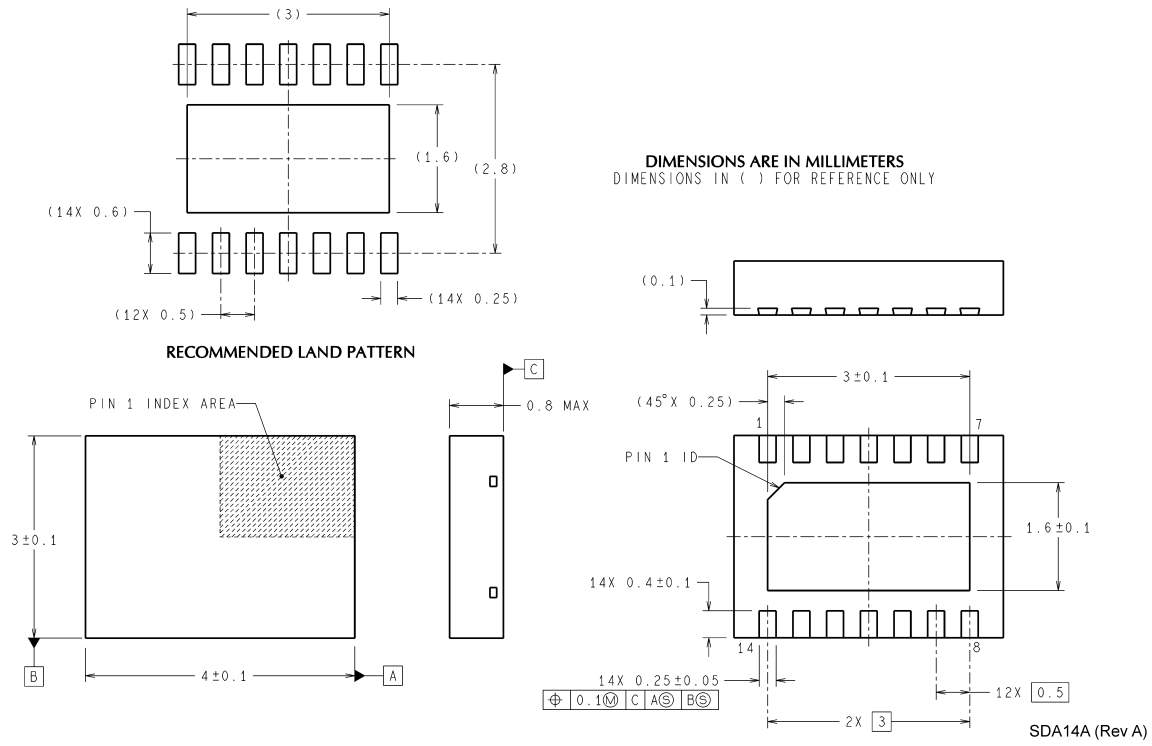

LIFE SUPPORT POLICY

NATIONAL'S PRODUCTS ARE NOT AUTHORIZED FOR USE AS CRITICAL COMPONENTS IN LIFE SUPPORT DEVICES OR SYSTEMS WITHOUT THE EXPRESS WRITTEN APPROVAL OF THE PRESIDENT AND GENERAL COUNSEL OF NATIONAL SEMICONDUCTOR CORPORATION. As used herein:

1. Life support devices or systems are devices or systems which, (a) are intended for surgical implant into the body, or (b) support or sustain life, and whose failure to perform when properly used in accordance with instructions for use provided in the labeling, can be reasonably expected to result in a significant injury to the user.
2. A critical component is any component of a life support device or system whose failure to perform can be reasonably expected to cause the failure of the life support device or system, or to affect its safety or effectiveness.

BANNED SUBSTANCE COMPLIANCE

National Semiconductor certifies that the products and packing materials meet the provisions of the Customer Products Stewardship Specification (CSP-9-111C2) and the Banned Substances and Materials of Interest Specification (CSP-9-111S2) and contain no "Banned Substances" as defined in CSP-9-111S2.

 <p>National Semiconductor Americas Customer Support Center Email: new.feedback@nsc.com Tel: 1-800-272-9959 www.national.com</p>	<p>National Semiconductor Europe Customer Support Center Fax: +49 (0) 180-530 85 86 Email: europe.support@nsc.com Deutsch Tel: +49 (0) 69 9508 6208 English Tel: +44 (0) 870 24 0 2171 Français Tel: +33 (0) 1 41 91 8790</p>	<p>National Semiconductor Asia Pacific Customer Support Center Email: ap.support@nsc.com</p>	<p>National Semiconductor Japan Customer Support Center Fax: 81-3-5639-7507 Email: jpn.feedback@nsc.com Tel: 81-3-5639-7560</p>
---	--	---	--

National does not assume any responsibility for use of any circuitry described, no circuit patent licenses are implied and National reserves the right at any time without notice to change said circuitry and specifications.